

The Stacking Sequence Optimization of Stiffened Laminated Curved Panels with Different Loading and Stiffener Spacing

Cheol Kim*, In-Se Yoon

*Department of Mechanical Engineering, Kyungpook National University,
1370 Sankyuk-Dong, Book-Gu, Daegu 702-701, Korea*

An efficient procedure to obtain the optimal stacking sequence and the minimum weight of stiffened laminated composite curved panels under several loading conditions and stiffener layouts has been developed based on the finite element method and the genetic algorithm that is powerful for the problem with integer variables. Often, designing composite laminates ends up with a stacking sequence optimization that may be formulated as an integer programming problem. This procedure is applied for a problem to find the stacking sequence having a maximum critical buckling load factor and the minimum weight. The object function in this case is the weight of a stiffened laminated composite shell. Three different types of stiffener layouts with different loading conditions are investigated to see how these parameters influence on the stacking sequence optimization of the panel and the stiffeners. It is noticed from the results that the optimal stacking sequence and lay-up angles vary depending on the types of loading and stiffener spacing.

Key Words : Stacking Sequence Optimization, Stiffened Composite Curved Panel, Genetic Algorithm, Finite Element Analysis

1. Introduction

Flight structures consist of many thin stiffened curved panels in order to save weight and buckling caused by propulsion and aerodynamic heating and pressure is an important design parameter. Especially, launch vehicles go through severe launching and re-entry environment such as compressive inertia force, surface pressure, and aerodynamic heating. Due to a high stiffness-to-weight ratio and a high strength-to-weight ratio, composite materials have greatly attracted the attention of many structural designers. Unlike isotropic materials, anisotropic materials have a different structural feature according to ply orienta-

tions and finding the optimal stacking sequence to satisfy the design requirements is very important. Optimization researches related to composite materials have been progressed continuously (Gürdal et al., 1999). Many structures composed of composite materials use limited ply orientations due to manufacturing difficulties. Many optimization methods have difficulties in handling such discrete variables as ply angles. Genetic algorithms (GAs), however, are suitable for representing discrete variables and reliable for convergence to a global minimum. Due to these reasons, GAs are increasingly applied to the optimization problems of the stacking sequence of composite laminates.

Le Riche and Haftka (1993) performed the optimization to maximize the critical buckling load of a panel under compression loads using genetic algorithms. Todoroki and Sasai (1999) used the recessive gene like the repair method to accomplish the optimization to maximize the critical buckling load of a composite cylinder. Liu et al. (2000) applied the permutation genetic algorithm

* Corresponding Author,

E-mail : kimchul@knu.ac.kr

TEL : +82-53-950-6586; **FAX :** +82-53-950-6550

Department of Mechanical Engineering, Kyungpook National University, 1370 Sankyuk-Dong, Book-Gu, Daegu 702-701, Korea. (Manuscript **Received** August 22, 2005;

Revised June 22, 2006)

to composite laminates. Soremenkun et al. (2001) applied the generalized elitist selection to the genetic algorithm. Soremenkun et al. (2001) also performed the optimization of multiple composite laminates using DARWIN. Stiffeners to prevent from buckling are so necessary that the number of researches on the stacking sequence optimization of stiffened laminated composite panels is increasing. Nagendra et al. (1996) minimized the weight of stiffened composite panels using an improved genetic algorithm. Kang et al. (2000) implemented the weight minimization of stiffened composite panels under uniaxial compression.

Most of papers reviewed above are, however, concerned about laminated stiffened flat panels under a simple uniaxial load. This is due to the functional limits of the in-house codes they developed. In this paper, an effective procedure to optimize the stacking sequence of stiffened composite curved panels is introduced considering stiffener layouts and various loads such as axial compression, aerodynamic pressure, and a thermal load. The design optimization combining the finite ele-

ment method and genetic algorithms have been performed using ABAQUS and DARWIN that are specialized for calculating stresses and optimizing the stacking sequence of composite laminated structures based on GAs, respectively. In addition, an interfacing code combining the two codes has been developed using Fortran. This stacking sequence optimization procedure may be applicable to any kinds of complicated laminated structures efficiently.

In this study the thickness of the panel is allowed to vary and the ply orientations are limited to 0° , $\pm 30^\circ$, $\pm 45^\circ$, and 90° for fabrication convenience, however, any angles can be readily adopted in this method. In addition, the geometry of stiffeners is fixed and the stacking sequence of stiffener web and flange is set to be $[0_2/90_2/(\pm 45)_2]_s$. The material used for these numerical studies is graphite/epoxy.

2. Buckling Analysis

Buckling analyses of laminated composite curv-

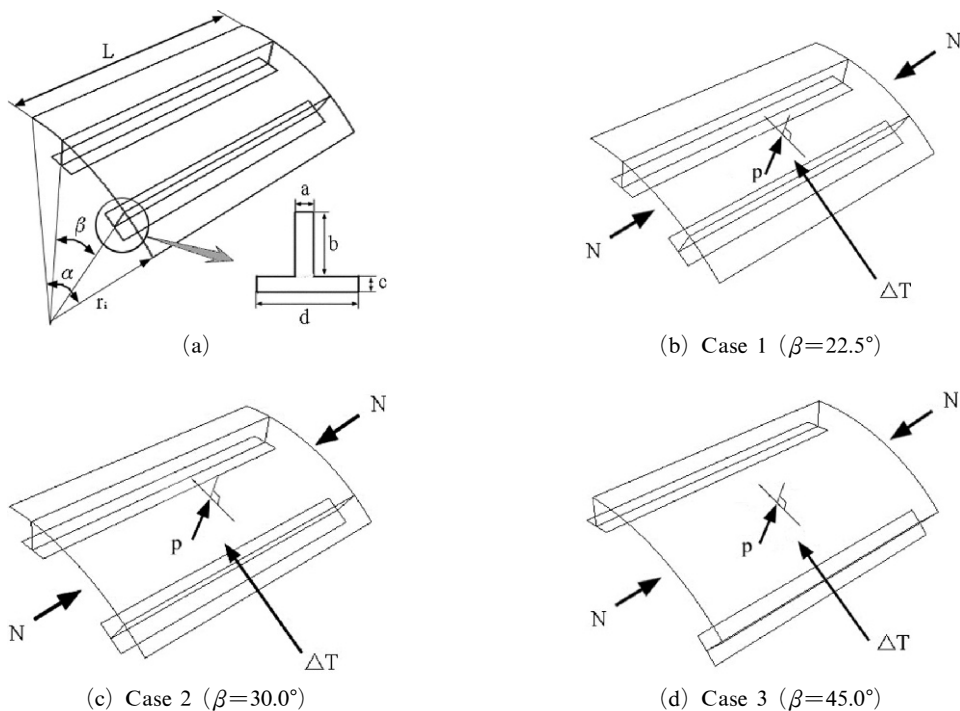

Fig. 1 (a) Geometry of a stiffened shell and stiffeners, and (b), (c), (d) analysis cases depending on the stiffener interval and loading condition

ed panels stiffened with two stiffeners are performed using FEM. Geometry of the stiffened composite panel used for numerical studies is described in Fig. 1 with the dimension as follows,

$$\alpha=45^\circ, \beta= 22.5^\circ \text{ (Case 1), } 30^\circ \text{ (Case 2), } 45^\circ \text{ (Case 3)}$$

according to a stiffener interval,
 $L=200 \text{ mm}, r_i=158.5 \text{ mm}$
 $a=2 \text{ mm}, b=20 \text{ mm}, c=2 \text{ mm}, d=20 \text{ mm}$

The finite element type S4R that is a 4-node doubly curved general-purpose shell element and allows transverse shear deformation is used for modeling the stiffened panel. It uses the thick shell theory as the shell thickness increases and becomes the discrete Kirchhoff thin shell elements as the thickness decreases. The transverse shear deformation becomes very small as the shell thickness decreases. The four edges of laminated composite shells are simply supported and 1200 elements and 1271 nodes are used for the analysis. Three types of loads such as axial compression (N), uniform pressure (p) normal to the surface, and thermal load (ΔT) are applied here in this study. The uniformly distributed temperature field is assumed so that no thermal gradients appear in the shell.

3. Genetic Algorithms

GAs seek to mimic the biological processes of reproduction and natural selection. Natural selection determines which members of a population survive to reproduce, and reproduction ensures that the species will continue. To employ GAs for engineering design optimization, the parameters of the design are usually encoded into a string of binary digits. The fitness of each string is determined according to required design specifications and individuals are selected with a probability proportional to their relative fitness. Genetic operators such as crossover and mutation change the genetic information of selected individuals and the next populations are generated. The flow chart of GAs is described in Fig. 2.

3.1 Genetic operator

The design parameters of GAs used in this

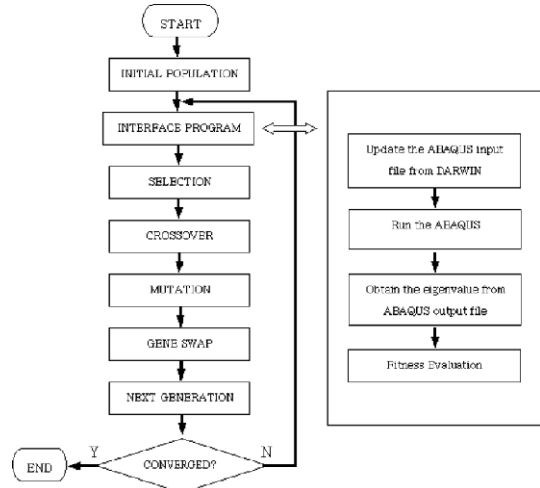

Fig. 2 Flow chart of GAs

Table 1 Design parameters of GAs

Parameters	Value
Population size	10
Probability of crossover	0.8
Probability of mutation	0.05
Probability of gene swap	0.9

paper are summarized in Table 1. The probability of mutation was set to be 0.05 and the value is normally recommended in the optimization of ply angles. Other values were adopted after reviewing other results by the same code and pre-analyses of some sample problems that gave good results.

3.1.1 Elitist selection

Elitist selection ranks a child population and a parent population separately. The best laminate from a parent population and the worst laminate from a child population are identified. To create a new population, the best design from a parent population replaces the worst laminate from a child population.

3.1.2 Crossover

Crossover is a genetic operator that combines two chromosomes to produce a new chromosome. The idea behind crossover is that the new chromosome may be better than both of the parents if it takes the best characteristics from each parent.

Crossover occurs during evolution according to a user-definable crossover probability. In this study, the one point crossover is used.

3.1.3 Mutation

Mutation is a genetic operator that alters one or more gene values in a chromosome from its initial state. This can result in entirely new gene values being added to the gene pool. With these new gene values, the genetic algorithm may be able to arrive at better solution than was previously possible. Mutation is an important part of the genetic search to prevent the population from stagnating at any local optima. Mutation occurs during evolution according to a user-definable mutation probability. This probability should usually be set fairly low. If it is set to high, the search will turn into a primitive random search.

3.1.4 Gene swap

Gene swap operator is implemented by randomly selecting two unique values in the string and switching their positions. Gene swap can be effective for problems where certain parts of the design string are set up faster than others.

3.2 Objective function

The weight of the stiffened shell can be expressed as

$$W = \pi \times [(r_i + N \times t)^2 - r_i^2] \times \frac{\alpha}{360} \times L \times \rho + 2 \times (ab + cd) \times L \times \rho \quad (1)$$

where r_i is the inner radius, N is the number of layers, α is the arc angle, L is the length of the shell, t is the ply thickness, ρ is the density and $a, b, c,$ are d the stiffener size as in Fig. 1(a). The goal of the optimization is to find the stacking sequence of the stiffened laminated composite shell, which minimizes the weight W . In other words,

$$\begin{aligned} & \text{Minimize} && W \\ & \text{Subject to} && \lambda \geq 1 \end{aligned} \quad (2)$$

where λ is a buckling load factor.

The fitness function F is calculated as follows,

$$F = \begin{cases} W \left(\frac{1}{\lambda}\right)^3 & 0.0 < \lambda < 1.0 \\ -W(1 - 0.0001\lambda) & \lambda \geq 1.0 \end{cases} \quad (3)$$

4. Numerical Results

In this study, the stacking sequence optimization based on GAs has been performed with the help of ABAQUS finite element analysis. An interface code connecting the GA-based optimization program with ABAQUS was developed using Fortran. The role of the interface code is described in the flow chart shown in Fig. 2. In the procedure, the interface code first updates an ABAQUS input file using the stacking sequence results obtained from a DARWIN run and then reruns ABAQUS buckling analysis. Then, eigenvalues from buckling analysis are used for calculating the fitness function. This process is repeated $n \times (p+1)$ times, where n is the number of members in a GA population and p is the number of generations. The material used for numerical studies is graphite/epoxy and its properties are given in Table 2. The optimization is performed to find the stacking sequence having the minimum weight subjected to various loads and satisfying the constraint of buckling load factor as well and then the effects of stiffener layouts on the stacking sequence are investigated.

4.1 Effects of loading types on the stacking sequence

The optimization of the stacking sequence under various loads has been implemented using

Table 2 Mechanical properties of graphite/epoxy

Properties		Value
E_1	GPa	125.36
E_2	GPa	6.49
G_{12}	GPa	2.78
G_{13}	GPa	2.78
G_{23}	GPa	2.46
ν_{11}		0.26
ρ	kg/m ³	1.578
Ply thickness	mm	0.125

Table 3 Optimal designs found according to various loads

Loading condition	No. of plies	Optimal design	Buckling load factor
Compression	11	$[90/0/\pm 30/0/\bar{0}]_s$	1.3327
Compression and pressure	10	$[90/45/0/-45/0]_s$	1.1068
Compression and thermal load	11	$[90/0/90/\pm 30/\bar{0}]_s$	1.2259
Compression, pressure and thermal load	11	$[90/\pm 30/0_2/\bar{0}]_s$	1.2778

the methodology developed above. The stiffener layout of Case 1 ($\beta=22.5^\circ$) is applied for this study.

4.1.1 Loading with the axial compression (N)

The stacking sequence and critical buckling load factor of the stiffened laminated composite panel are investigated when the panel is loaded with the axial compression. The magnitude of the axial compression 50 kN is imposed. The four edges of the panel are simply supported. The results are summarized in Table 3. The optimal stacking sequence solution of $[90/0/\pm 30/\bar{0}]_s$ is obtained and it is corresponding to 11 plies.

4.1.2 Loading with the combined axial compression (N) and pressure (p)

The stiffened shell is under the uniform pressure and axial compression. The pressure difference of 1atm is loaded uniformly on the skin of the panel outwardly. The results are shown in Table 3. The optimal stacking sequence solution is $[90/45/0/-45/0]_s$ which has 10 plies. The result shows that the outward pressure is advantageous to improvement of the buckling strength.

4.1.3 Loading with the combined axial compression (N) and thermal load (ΔT)

The thermal load and the axial compression are together loaded on the panel. The thermal load takes place by raising temperature from $T_0=20^\circ\text{C}$ to $T_1=1,520^\circ\text{C}$. In the static equilibrium considered here, a uniformly distributed temperature field with $T=T_1$ is assumed throughout the panel. Therefore, no thermal gradients appear in the panel. The optimal design is $[90/0/90/\pm 30/\bar{0}]_s$ as shown in Table 3 and it is noticed that the buckling load factor decreases as being compared

with the case of compression only.

4.1.4 Loading with the combined axial compression (N), pressure (p) and thermal load (ΔT)

The pressure, thermal load and axial compression are loaded on the panel at the same time. The result is shown in Table 3. The optimal design is $[90/\pm 30/0_2/\bar{0}]_s$ and the buckling load factor increases due to the influence of outward pressure compared with the load case of the axial compression and thermal load.

4.2 Effect of stiffener layouts on the stacking sequence

The changes in the stacking sequence and buckling load factor depending on the three types of stiffener layouts, $\beta=22.5^\circ$ (Case 1), 30° (Case 2), 45° (Case 3) illustrated in Figs. 1(b), (c), and (d) have been investigated. The combined outward pressure, thermal load and axial compression are loaded on the panel at the same time. The optimal solutions are shown in Table 4. The optimal designs are $[90/\pm 30/0_2/\bar{0}]_s$, $[90/45/0/-45/90/\bar{90}]_s$, and $[90_2/\pm 30/0/\bar{0}]_s$ for each stiffener layout case. In general, as the interval between two stiffeners increases, the value of a buckling load factor decreases. However, the buckling load factor of Case 3 here is larger than that of Case 2. This is due to the fact that the longitudinal stiffness of the Case 3 stacking sequence is higher than that of Case 2. The enlarged deformations with the optimal designs for each case are illustrated in Fig. 3. All cases as shown in Fig. 4 converged to their optimum design after 15 to 24 iterations with a stopping criterion that the number of iteration reaches to more than 10 times without further improvement.

Table 4 Optimal designs according to stiffener layouts

Stiffener layout	No. of plies	Optimal design	Buckling load factor
Case 1 ($\beta=22.5^\circ$)	11	$[90/\pm 30/0_2/\bar{0}]_s$	1.2778
Case 2 ($\beta=30^\circ$)	11	$[90/45/0/-45/90/90]_s$	1.0015
Case 3 ($\beta=45^\circ$)	11	$[90_2/\pm 30/0/\bar{0}]_s$	1.1946

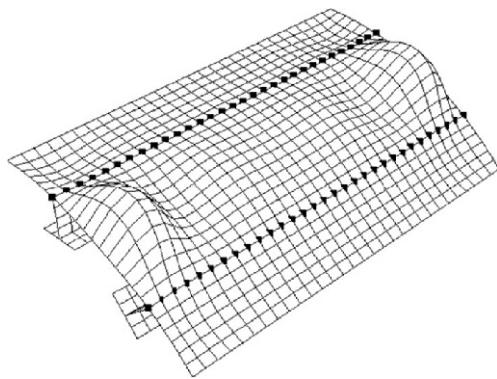

(a) Case 1 ($\beta=22.5^\circ$)

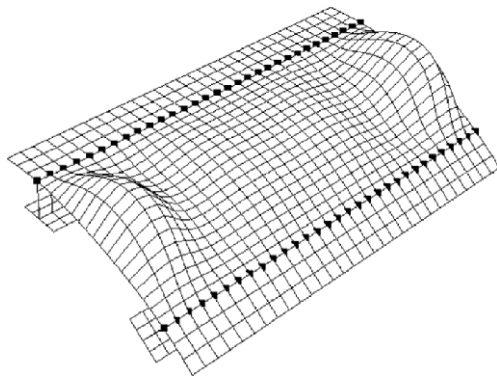

(b) Case 2 ($\beta=30.0^\circ$)

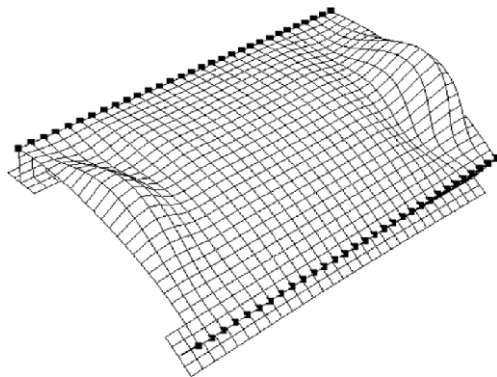

(c) Case 3 ($\beta=45.0^\circ$)

Fig. 3 The enlarged deformations with the designs of the optimized stacking sequence

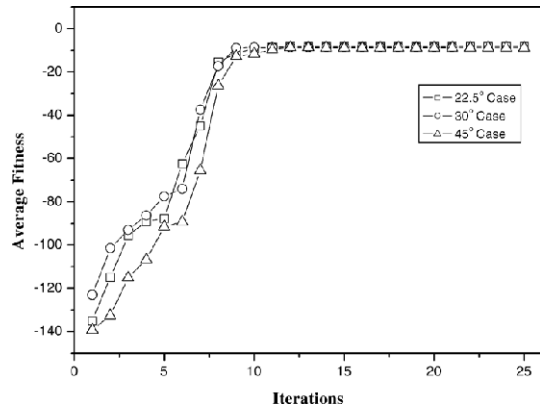

Fig. 4 Converging history according to stiffener layouts

5. Conclusions

An efficient method to optimize the stacking sequence of stiffened composite curved panels has been developed by combining the finite element analysis, genetic algorithms and interfacing data transfer. Three types of loading such as outward normal pressures, axial compressions, and thermal loads that realistically happen during a high-speed flight are considered. In addition, the effects of the buckling load factor and different types of stiffener layouts on the optimization of the stacking sequence of the stiffened laminated shells were investigated under different load conditions. All cases converged to their optimum design after 15 to 24 iterations with a stopping criterion that the number of iteration reaches to more than 10 times without further improvement. The effect of the existence of outward pressures is favorable to the optimization due to the increase in the buckling load factor. It is noticed that the optimal stacking sequence and lay-up angles vary depending on the types of loading and stiffener spacing. Therefore, the choice of the stacking sequence should

be careful when the loading is complex and the choice can be readily determined by the proposed method regardless of geometric complexity.

References

- Gürdal, Z., Haftka, R. T. and Hajela, P., 1999, *Design and Optimization of Laminated Composite Material*, John Wiley & Sons Inc., New York.
- Kang, J. H., Kim, J. S., Kong, C. W., Kim, C. G. and Hong, C. S., 2000, "Optimal Design of Compressively Loaded Stiffened Composite Panels using Genetic Algorithm," *Journal of The Korean Society for Aeronautical and Space Sciences*, Vol. 28, No. 3, pp. 72~81.
- Le Riche, R. and Haftka, R. T., 1993, "Optimization of Laminated Stacking Sequence for Buckling Load Maximization by Genetic Algorithm," *AIAA Journal*, Vol. 31, No. 5, pp. 951~956.
- Liu, B., Haftka, R.T., Akgün, M. A. and Todoroki, A., 2000, "Permutation Genetic Algorithm for Stacking Sequence Design of Composite Laminates," *Comput. Methods Appl. Mech. Engrg.*, Vol. 186, pp. 357~372.
- Nagendra, S., Jestin, D., Gürdal, Z., Haftka, R. T. and Watson, L. T., 1996, "Improved Genetic Algorithm for the Design of Stiffened Composite Panels," *Computers and Structures*, Vol. 58, pp. 543~555.
- Soremenkun, G., Gürdal, Z., Haftka, R. T. and Watson, L. T., 2001, "Composite Laminate Design Optimization by Genetic Algorithm with Generalized Elitist Selection," *Computers and Structures*, Vol. 79, pp. 131~143.
- Soremenkun, G., Gürdal, Z., Kassapoglou, C. and Toni, D., 2001, "Stacking Sequence Blending of Multiple Composite Laminates Using Genetic Algorithm," *Proc. 42nd AIAA/ASME/ASCE/AHS/ASC SDM. Conf., Seattle, WA*, AIAA 2001-1203.
- Todoroki, A. and Sasai, M., 1999, "Improvement of Design Reliability for Buckling Load Maximization of Composite Cylinder Using Genetic Algorithm with Recessive-Gene-Like Repair," *JSME International Journal, Series A*, Vol. 42, No. 4, pp. 530~536.